

LED LIGHTING REQUIREMENTS OF 1X6 KEYPADS

The keypad may be lighted using various voltage sources as long as a current limiting circuit is provided. The recommended current limiting circuit includes user-supplied resistors as shown on the following figures. The V_S is the voltage source, and pin 1 through pin 7 are the pins of green and red LED lighting connectors.

The recommended resistor value for the green LED lighting connector (R_G), resistor value for the red LED lighting connector (R_R), minimum resistor power rating for the green LED lighting connector (P_{RG}), minimum resistor power rating for the red LED lighting connector (P_{RR}) for a given power supply voltage source (V_S) are shown on the following tables. Also shown are the minimum power supply power rating (P_S).

If the voltage source is not listed on the tables, P_S , R_G , R_R , P_{RG} , and P_{RR} are determined by evaluating the equations which follow. The following equations are derived for a lighted 1X6 keypad that has six (n) pushbuttons (LEDs) with 20 mA forward current (i) per LED, 2.0 V green LED forward voltage (V_{LG}), and 1.7 V red LED forward voltage (V_{LR}).

Recommended Power Supply and Resistor to Individually Light Each Pushbutton

A pushbutton LED is lighted by grounding its cathode.

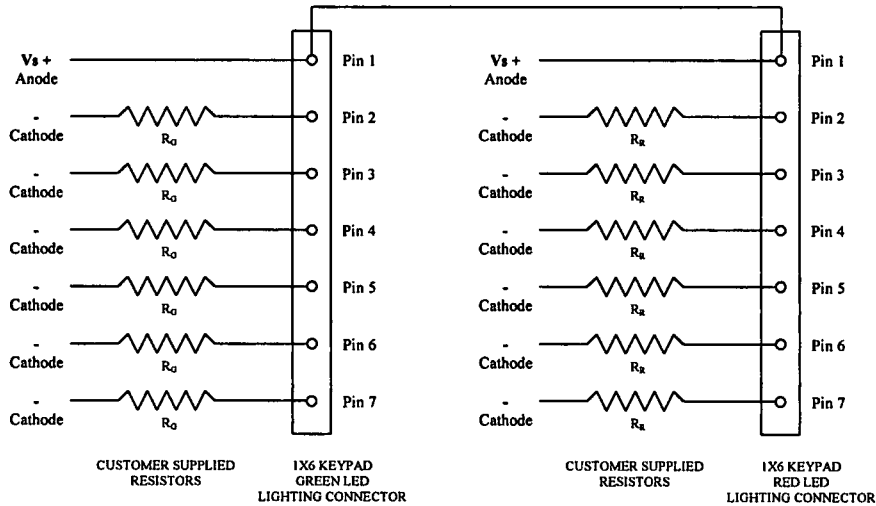

Resistors to Light Individual Pushbutton Green or Red

Power Supply and Resistor to Light Individual Pushbutton Green or Red

Power Supply		Resistor for Green LED		Resistor for Red LED		Pushbutton		Green LED	Red LED
V_S (V)	P_S min (W)	R_G (Ω)	P_{RG} min (W)	R_R (Ω)	P_{RR} min (W)	TOTAL (n)	i (A)	V_{LG} (V)	V_{LR} (V)
5	0.60	150	0.06	165	0.07	6	0.02	2.0	1.7
12	1.44	500	0.20	515	0.21	6	0.02	2.0	1.7
14	1.68	600	0.24	615	0.25	6	0.02	2.0	1.7
28	3.36	1300	0.52	1315	0.53	6	0.02	2.0	1.7

Power Supply and Resistor Equations to Light Individual Pushbutton

$$P_S = niV_S$$

$$R_G = \frac{V_S - V_{LG}}{i}$$

$$R_R = \frac{V_S - V_{LR}}{i}$$

$$P_{RG} = i^2 R_G$$

$$P_{RR} = i^2 R_R$$

Recommended Power Supply and Resistor to Simultaneously Light All Pushbuttons

NOTE:

Since the anodes of the green LEDs and the anodes of the red LEDs are tied together to pin 1 green LED lighting connector and pin 1 red LED lighting connector, each current limiting resistor has to be placed on the cathode side of the connector. The pushbuttons are lighted by bringing the cathode to ground.

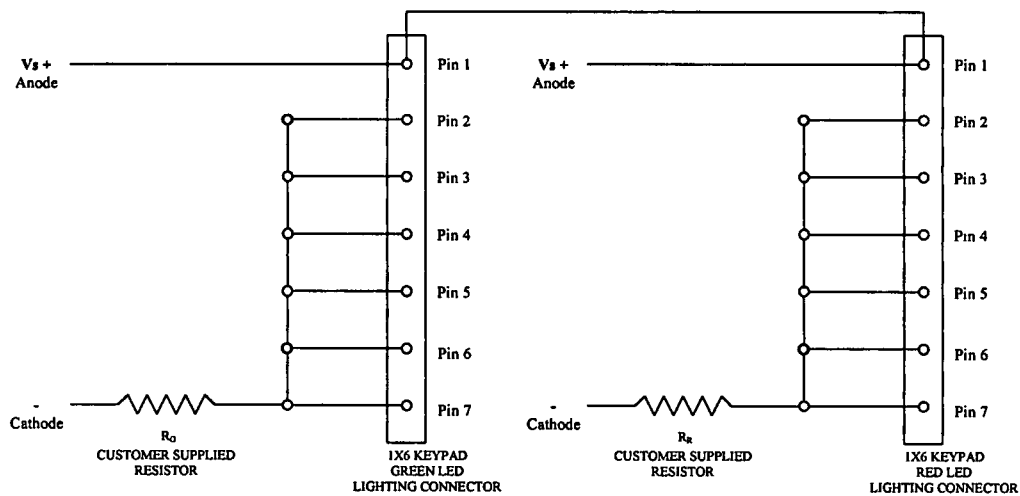

Resistors to Light All Pushbuttons Green or Red

Power Supply and Resistor to Light All Pushbuttons Green or Red

Power Supply		Resistor for Green LED		Resistor for Red LED		Pushbutton		Green LED	Red LED
V _S (V)	P _S min (W)	R _G (Ω)	P _{RG} min (W)	R _R (Ω)	P _{RR} min (W)	TOTAL (n)	i (A)	V _{LG} (V)	V _{LR} (V)
5	0.60	25.00	0.36	27.50	0.40	6	0.02	2.0	1.7
12	1.44	83.33	1.20	85.83	1.24	6	0.02	2.0	1.7
14	1.68	100.00	1.44	102.50	1.48	6	0.02	2.0	1.7
28	3.36	216.67	3.12	219.17	3.16	6	0.02	2.0	1.7

Power Supply and Resistor Equations to Light All Pushbuttons

$$P_S = niV_S$$

$$R_G = \frac{V_S - V_{LG}}{ni}$$

$$R_R = \frac{V_S - V_{LR}}{ni}$$

$$P_{RG} = (ni)^2 R_G$$

$$P_{RR} = (ni)^2 R_R$$